



This taper offers the option of a high speed system that can seal random sized cases at speeds of up to 18 per minute, with no manual adjustment for each size of case.

Features of the 714 include:

Floating Bridge



Fitted as standard to all our case sealers, the floating bridge allows the machine to accept swollen or out-of-specification cases while providing consistent and accurate sealing. This feature also allows quick access to the bottom tapehead with no need to readjust the machine.

Twin Column Construction



The use of our unique twin column design provides added stability for the taping bridge to ensure the machine runs smoothly at all times with minimal interruption and it provides the support necessary for the floating bridge feature.

Interchangeable Tape Heads



The 714 uses any machine tape up to 50mm wide, 1000m long and features instantly removable, interchangeable tapeheads, easily threaded, with integral knife guards.

Ease of Operation



Simple mechanical operation and clear access for easy cleaning and maintenance make this an efficient and straightforward machine to operate. Fitted as standard with a steel roller infed table and braked castors.

Robust Construction



High quality components housed in a robust chassis ensure minimal servicing and enable 24 hour operation. The 714 is designed for the rigours of typical end-of-line packaging environments.

Extended Warranty



Two year fully comprehensive warranty for peace of mind and reduced cost of ownership.



714

Semi-Automatic Random Case Taper

Options include:

- High speed system up to 18 cases/minute
- Sealing cases down to 50mm high possible with guarding
- Low tape sensing
- No tape/low tape sensing
- Visual/audible alarm
- Discharge blocked sensor

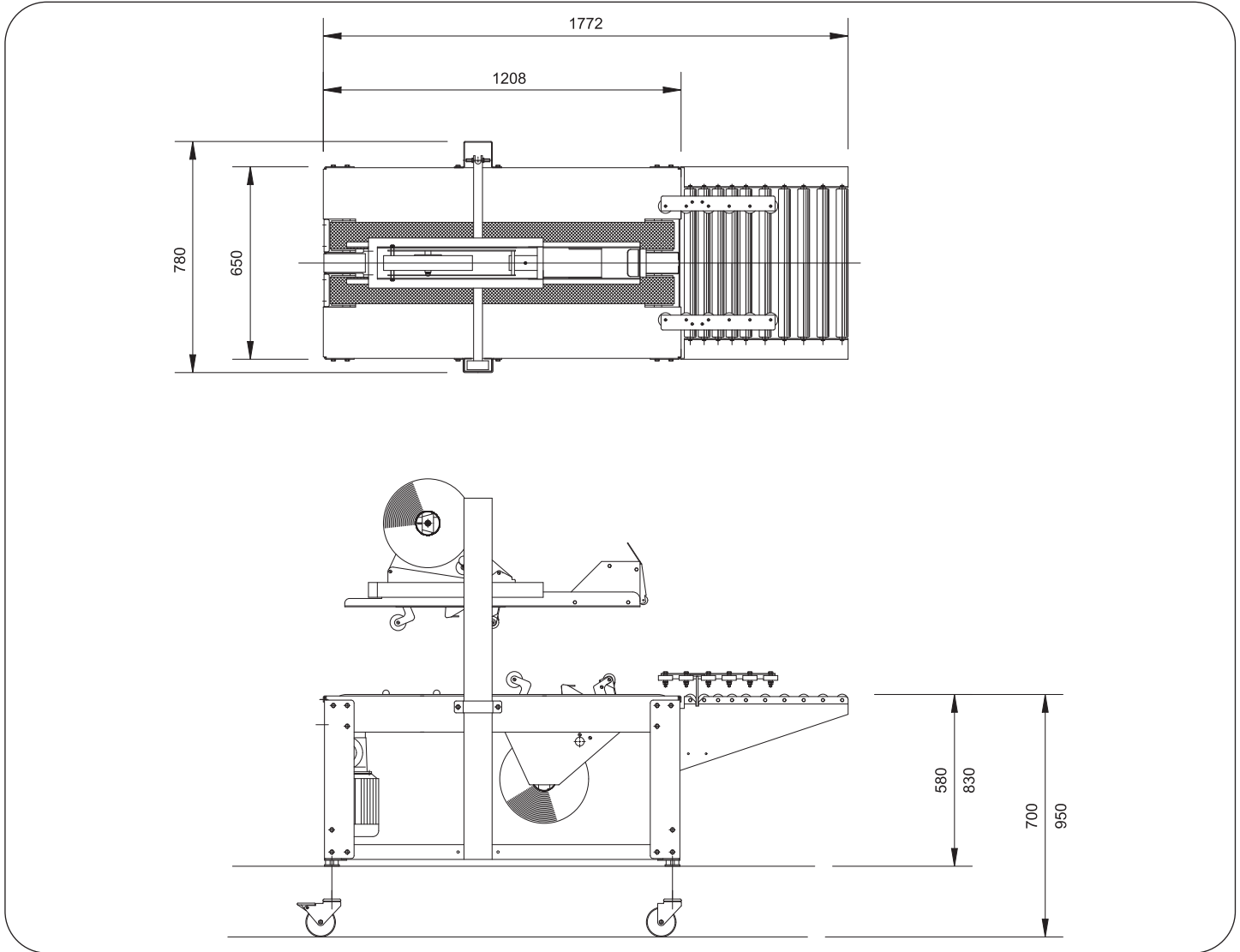

Case Dimensions (mm)

	Length	Width	Height
Minimum	185	140	110
Maximum	inf	460	520



Endoline Machinery Limited
Stratton Business Park, London Road
Biggleswade, Bedfordshire
SG18 8QB
United Kingdom

Telephone: +44 (0) 1767 316422
Facsimile: +44 (0) 1767 318033
E-mail: sales@endoline.co.uk
Website: www.endoline.co.uk

Electrical Supply

Single phase: 240V, 50Hz
Three phase: 415V, 50Hz

Machine Finish

Mild steel, powder coated white (RAL9010) or stainless steel

Pneumatics

80psi (5.5 bar)

Tape Size

Standard: up to 50mm wide
Optional: up to 75mm wide

© Endoline reserves the right to change specifications without prior notice.